

800x68mm SQF SELF INSTALLATION GROUND SCREW

DIMENSIONS: Pipe - 68 x 2 x 800mm
Flange – 76 x 6 x 76mm

MATERIALS: Steel Type – Q235
Coating – Hot Dip Galvanised

INSTALLATION: Manual Installation

PROJECT TYPES: Lightweight Construction Applications

FIXING: M16 Captive Nut

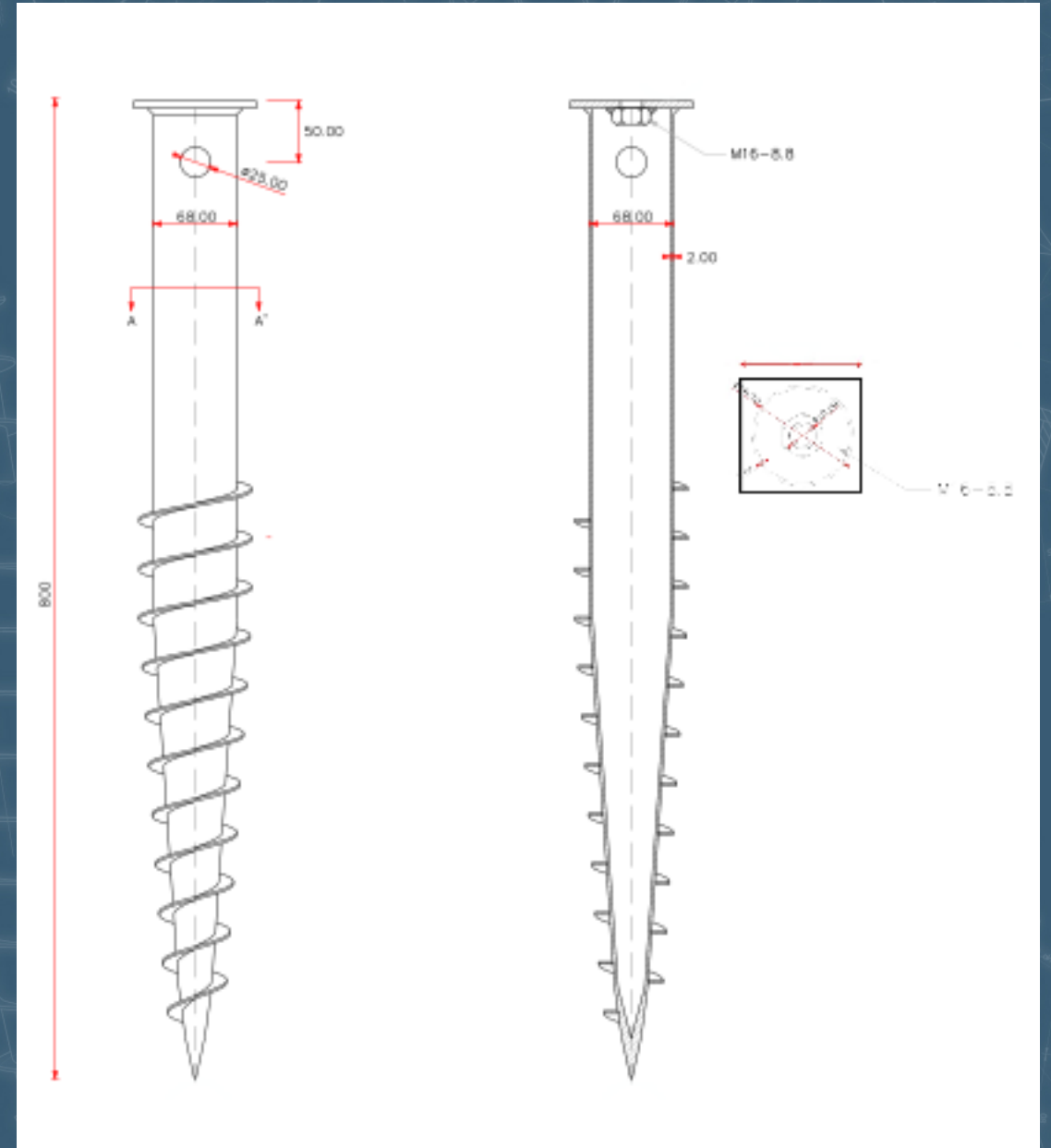

The Great British Ground Screw Company Limited
Units 8 E & F Bowburn South Industrial Estate, Durham DH6 5AD
Tel: +44 (0)191 5805023 info@gbgs.co.uk